

# Nationale Biobased Conferentie

## Biobased, circulair, dampopen & gezond

ing. Laurens Taal







Integraal duurzaam ontwerpen





Bouwbesluit

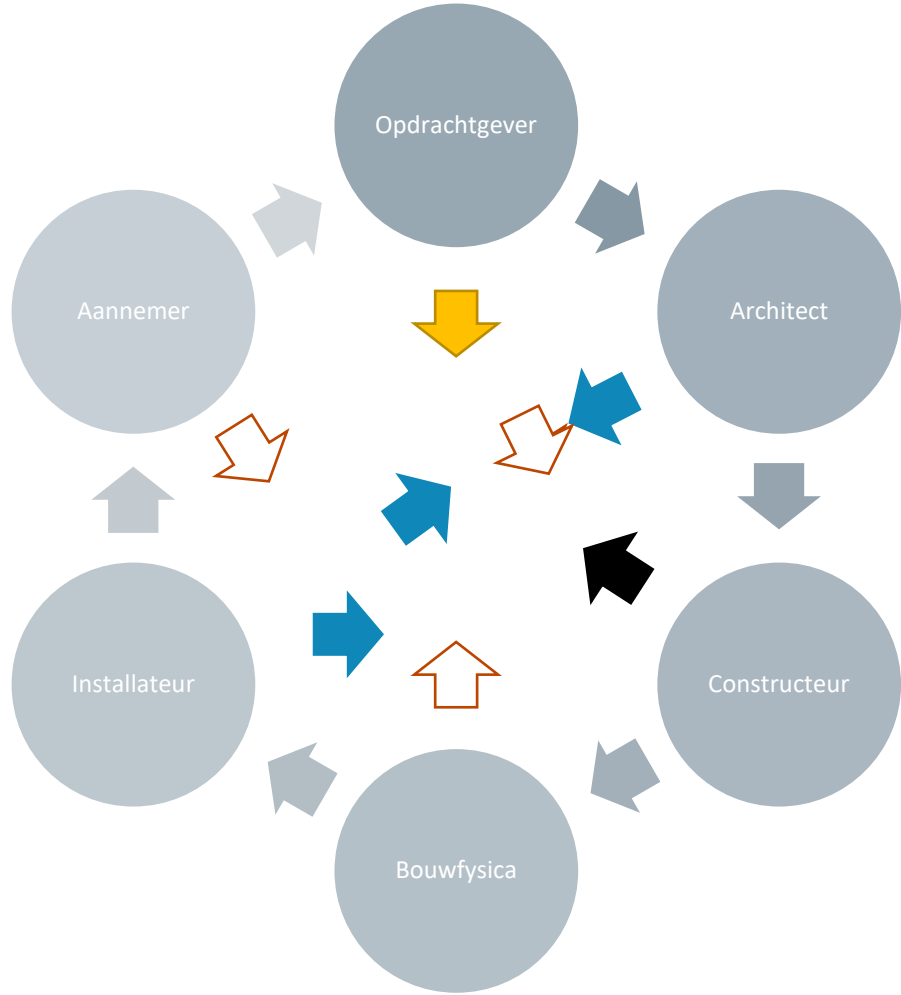
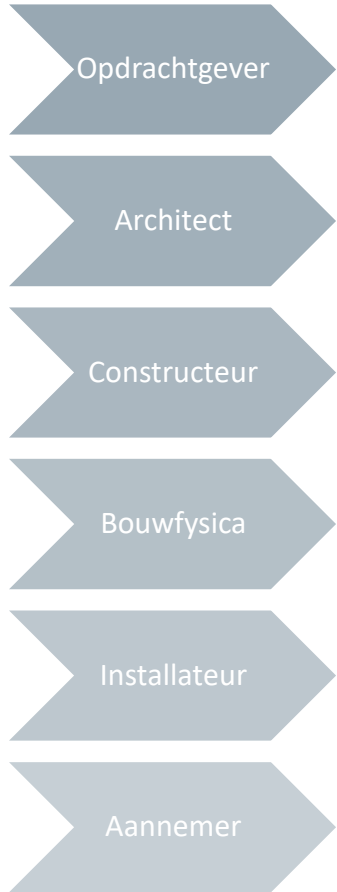

Verbindt en creëert



water

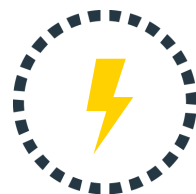

energie



afval



groen



materialen  
& grondstoffen



sociale  
duurzaamheid



mobiliteit &  
transport





afval



water



groen

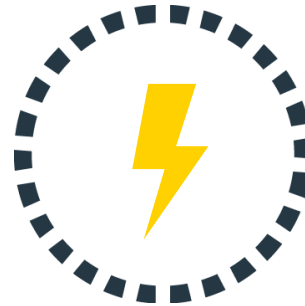

energie



materialen &  
grondstoffen



sociale  
duurzaamheid



mobiliteit &  
transport



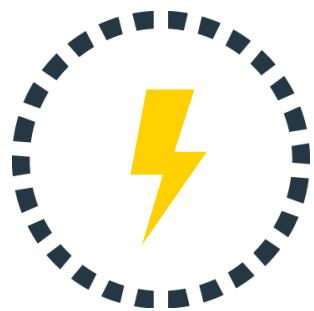

energie

**ENERGIE  
LEVEREND**

**ENERGIE  
NEUTRAAL**

**BENG**

**PASSIEF**

**NOM**

**ENERGIEINDEX**

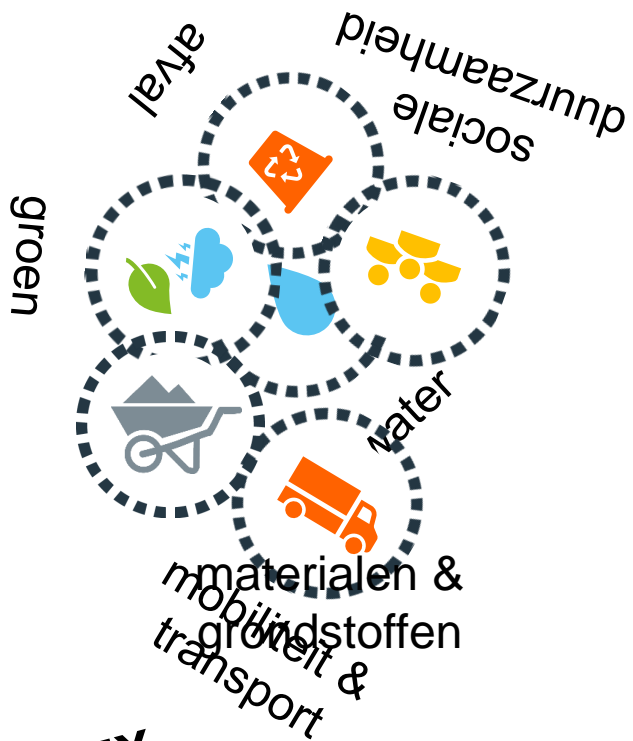



energie



water



groen



materialen &  
grondstoffen



afval



sociale  
duurzaamheid



mobiliteit &  
transport





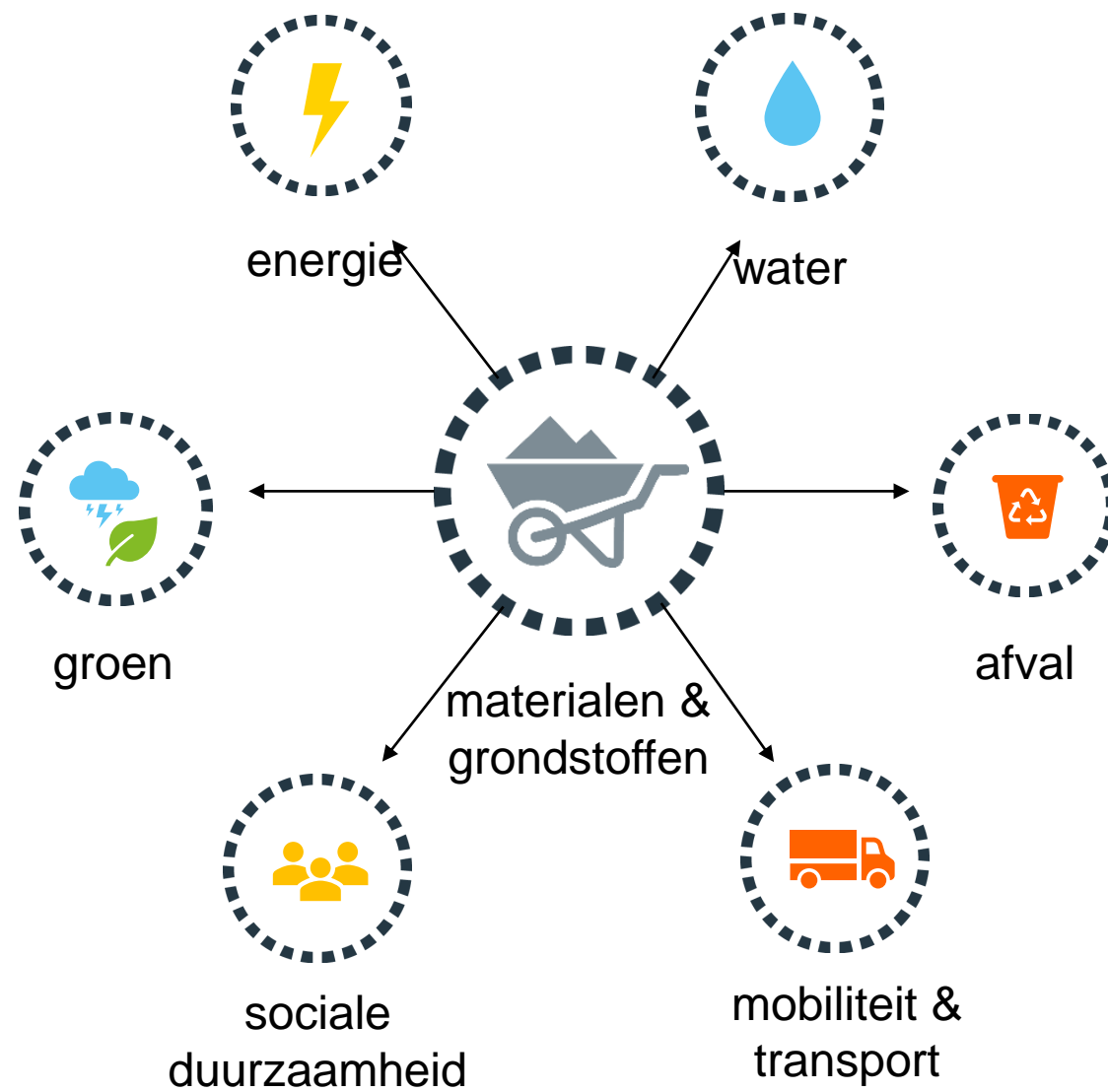



# Integraal duurzaam ontwerpen

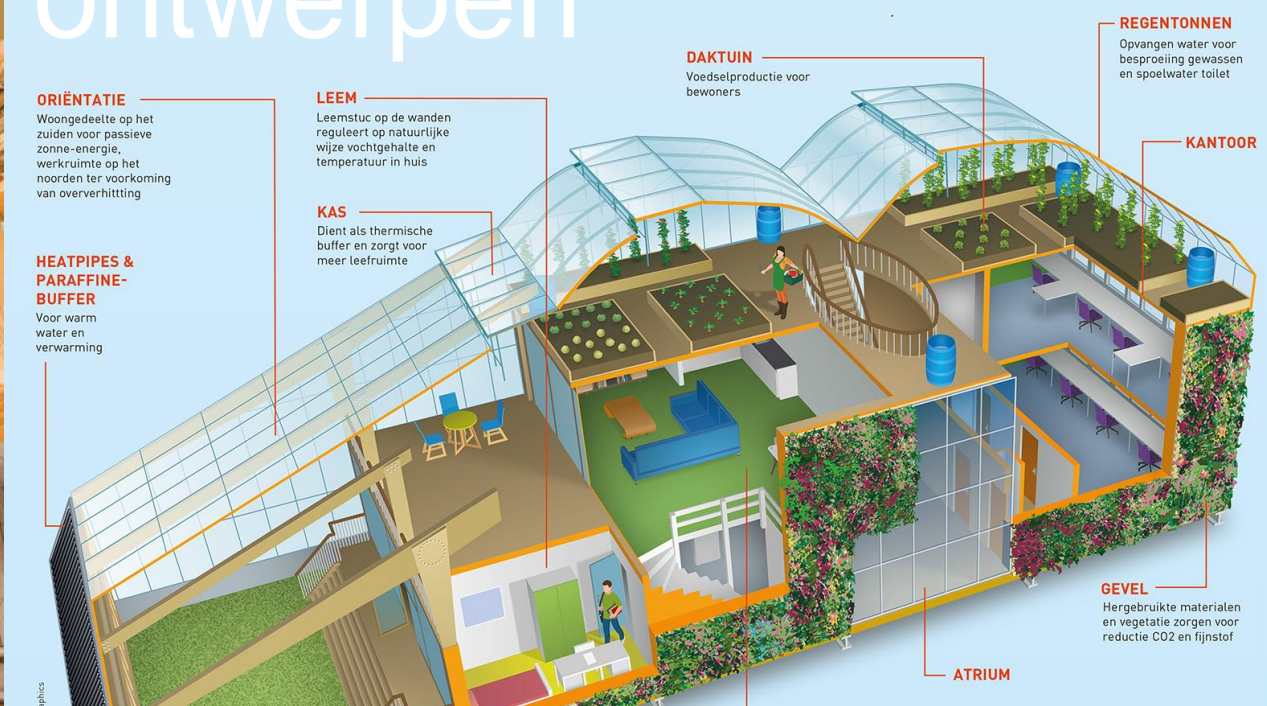



# Integraal duurzaam ontwerpen

## Grondstof en bouwsysteem





**CLT / Cross Nailed Timber**



**Traditioneel houtskeletbouw**



**Houten I-liggers**

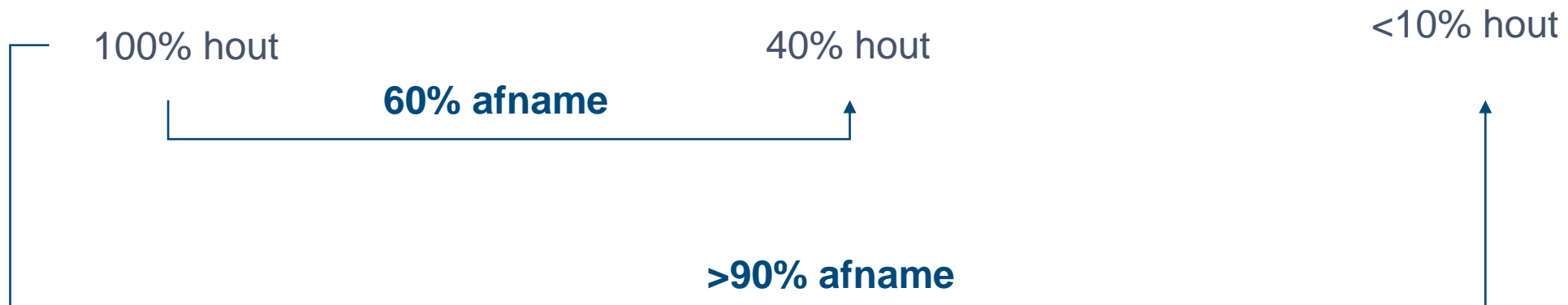



## Is de houten I-ligger niet duurder dan SLS?

- ▶ Ja, maar....
  - ▶ Grotere vormvastheid, dus nauwkeuriger bouwen met meer luchtdichtheid
  - ▶ Minder koudebrug, hogere isolatiewaarde
  - ▶ Lichter, dus i.h.w. of met lichter materieel te plaatsen. Bouwkraan? Fundering?









# Integraal duurzaam ontwerpen

*Duurzaam = meerkosten?*



8 december 2021



## Wandopbouw met leemstucplaat, I- liggers en cellulose vs. traditioneel HSB

- ▶ In prijsafweging: leemstucplaat niet prijsconcurrerend te krijgen tegen een gipskartonplaat
  - ▶ Echter: door geen kosten van bouwfolies, minder arbeidskosten, sneller isolatie inblazen is het systeem als geheel wél concurrerend in prijs.
  - ▶ Het systeem is dampopen en kan een bijdrage leveren aan een low-tech installatiearm bouwsysteem.
- Installatiekosten kunnen lager worden.

Gipskarton: € 6,38 per m<sup>2</sup>



SINIAT Gipswandplaat HYDRO afgeschuinde kant voor vochtige ruimte 2600 x 600 x 12,5 mm



**6,38 \*** / m<sup>2</sup>  
(9,95 \* / Stuks)

Bij afname van 156 m<sup>2</sup> :  
**5,74 \*** / m<sup>2</sup> (8,95 \* / Stuks)

Art. 8908016

- Type artikel: Plaat
- Toepassingsgebied: Wand

Leembouwplaat €20,75 per m<sup>2</sup>



### LEMIX LEEMBOUWPLAAT.

LEM16: LEMIX LEEMBOUWPLAAT 16MM

Lemix leembouwplaat is een goede vervanging voor de gipskartonplaat. De Lemix leembouwplaten hebben voldoende massa waardoor de plaat sterk en beter te verwerken is. Daarnaast bevat de plaat geen riet waardoor het verwerken eenvoudiger gaat.

**€ 16,21/1 st.**  
(€19,61 inc. btw)

VARIANT  
LEMIX LEEMBOUWPLAAT 16MM ▾

	breedplaat 280		Lignature	
basis lev & aanbr	€ 85-95		€ 185-195	
stempels	-	incl	-	nvt
veiligheidsvoorz	-	incl	€ 10	excl
kraan	-	incl	-	incl
vloerafwerking	€ 35	zwevend	€ 35	zwevend
plafondafwerking	€ 6,50	spack	€ 45	verlaagd
akoestiek	-	massa vloer	€ 65	akoest spuitw
installaties	-	in vloer	-	onder plaf
brand	-	incl	-	30 min?*
stabiliteit	-	incl	-	koppelen vloeren
<b>Totaal prijs/m2</b>	<b>€ 126-136</b>		<b>€ 340-350</b>	

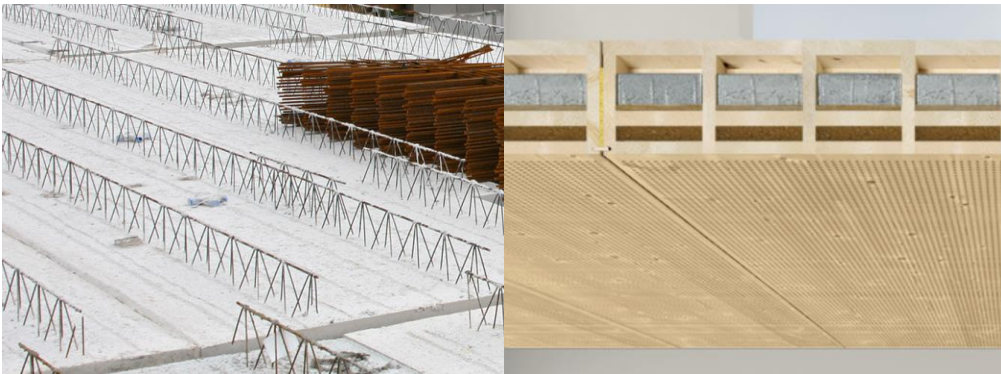

## Betonvloer versus prefab hout

- ▶ Calculator maakt onjuiste vergelijking
- ▶ Snellere bouw, geen droogtijd → eerder de verhuur / verkoop in?
- ▶ Beproefde detaillering, all-in-one oplossing
  - ▶ Constructief, geluid, akoestiek, brandveiligheid, esthetiek



# Integraal duurzaam ontwerpen

*Dampopen bouwen*





Verbindt en creëert

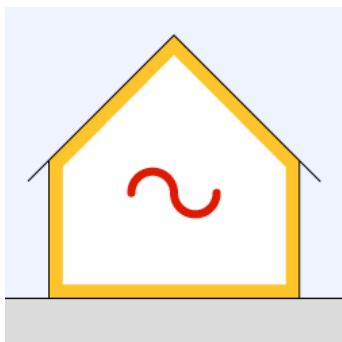

Hoogwaardig  
isoleren

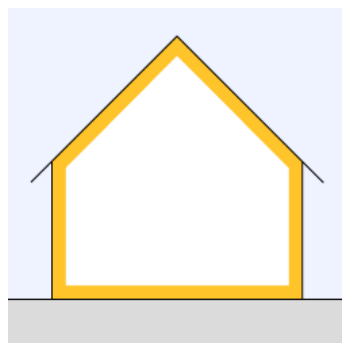

Luchtdicht  
bouwen

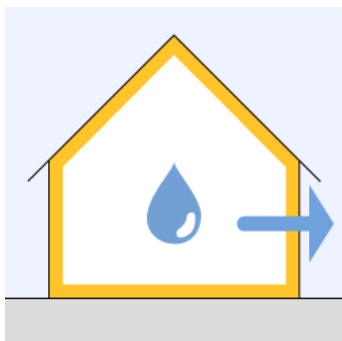

Dampopen  
bouwen

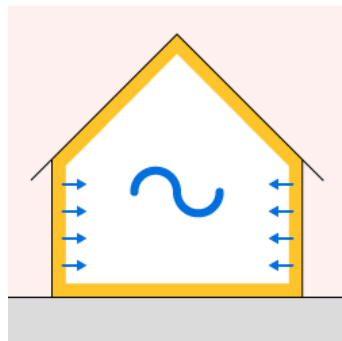

Bouwmassa  
capillair biobased



Steeds weer nieuwe avonturen  
Zaza de kakerlak bijvoorbeeld, en Delle de de  
Pen, de Stampertje en Abgie. Samen met het  
steeds weer nieuwe  
- Annie M.G. Sch



# Voorverkenning in Ubakus

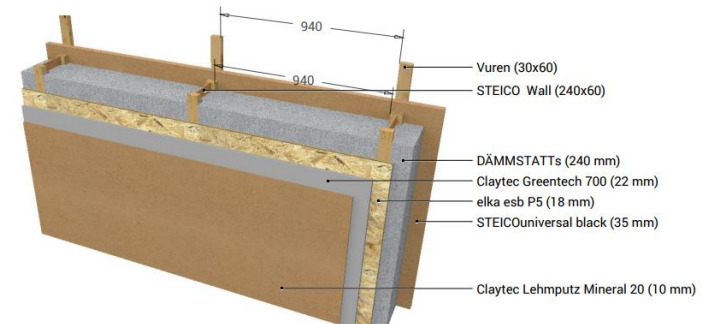
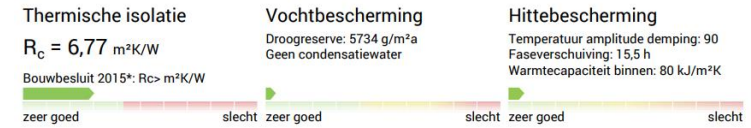
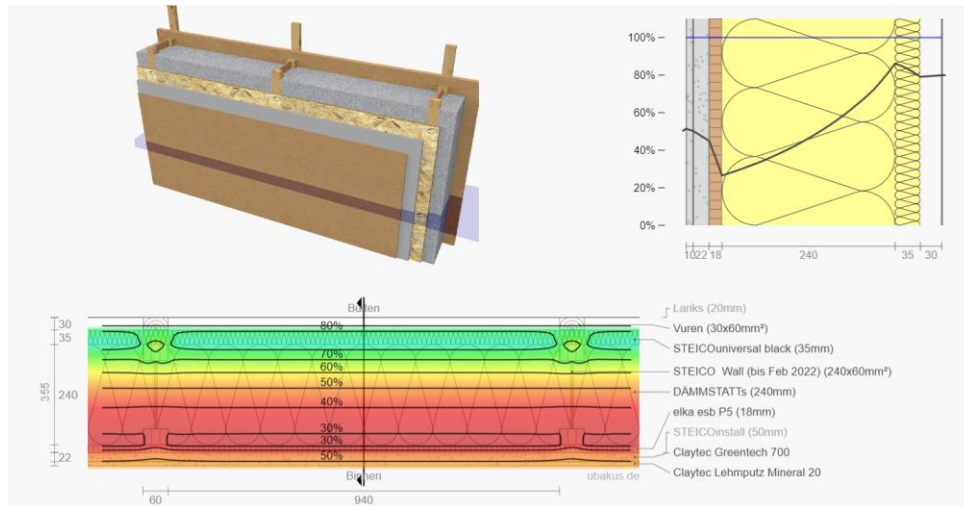
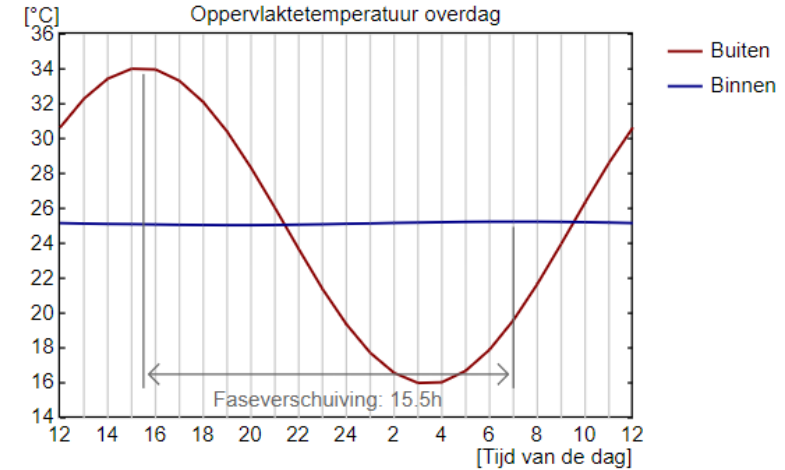
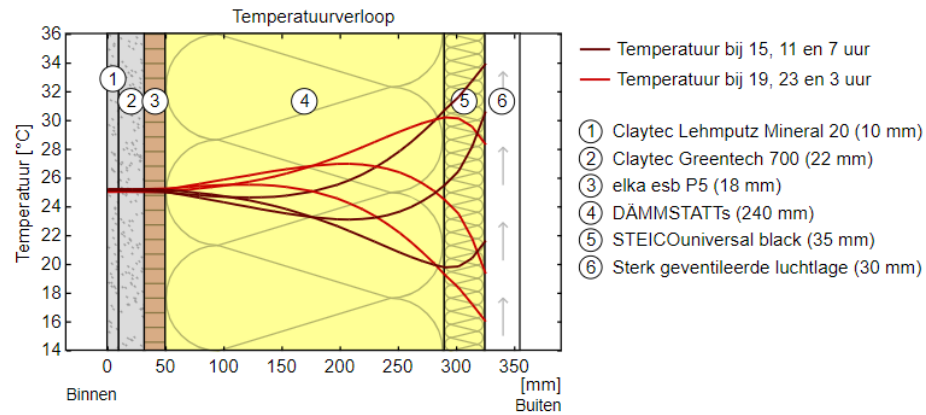

# Gevoelige details in WUFI

Wood pore RHWTA 6-8

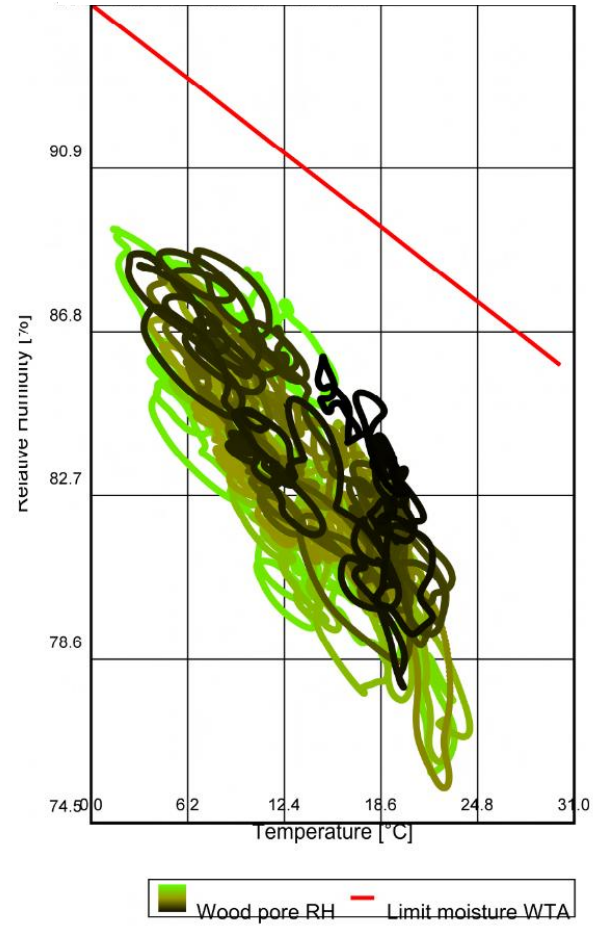

Total Water Content

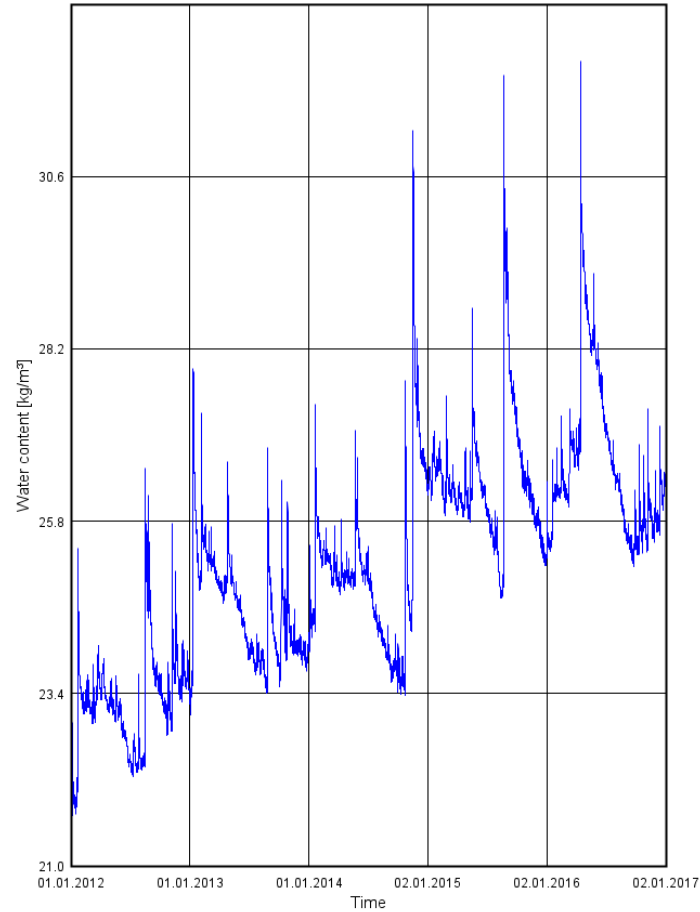

Water Content metselwerk binnen

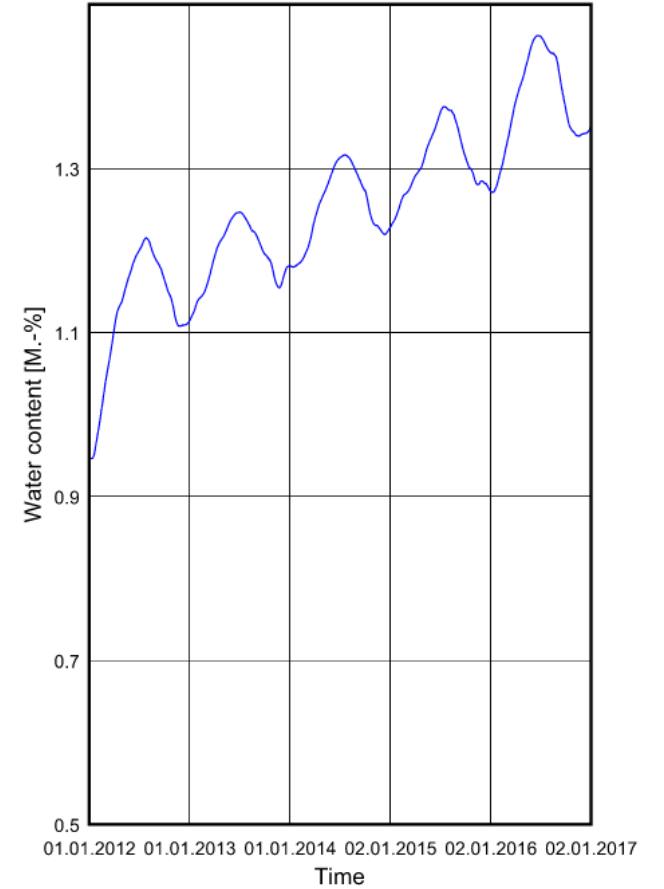



# Laurens Taal

**Projectleider duurzaamheid**

06 206 89975

[ltaal@avecodebondt.nl](mailto:ltaal@avecodebondt.nl)

